

# Инструкция по сборке

Руф

Шкаф распашной - 6

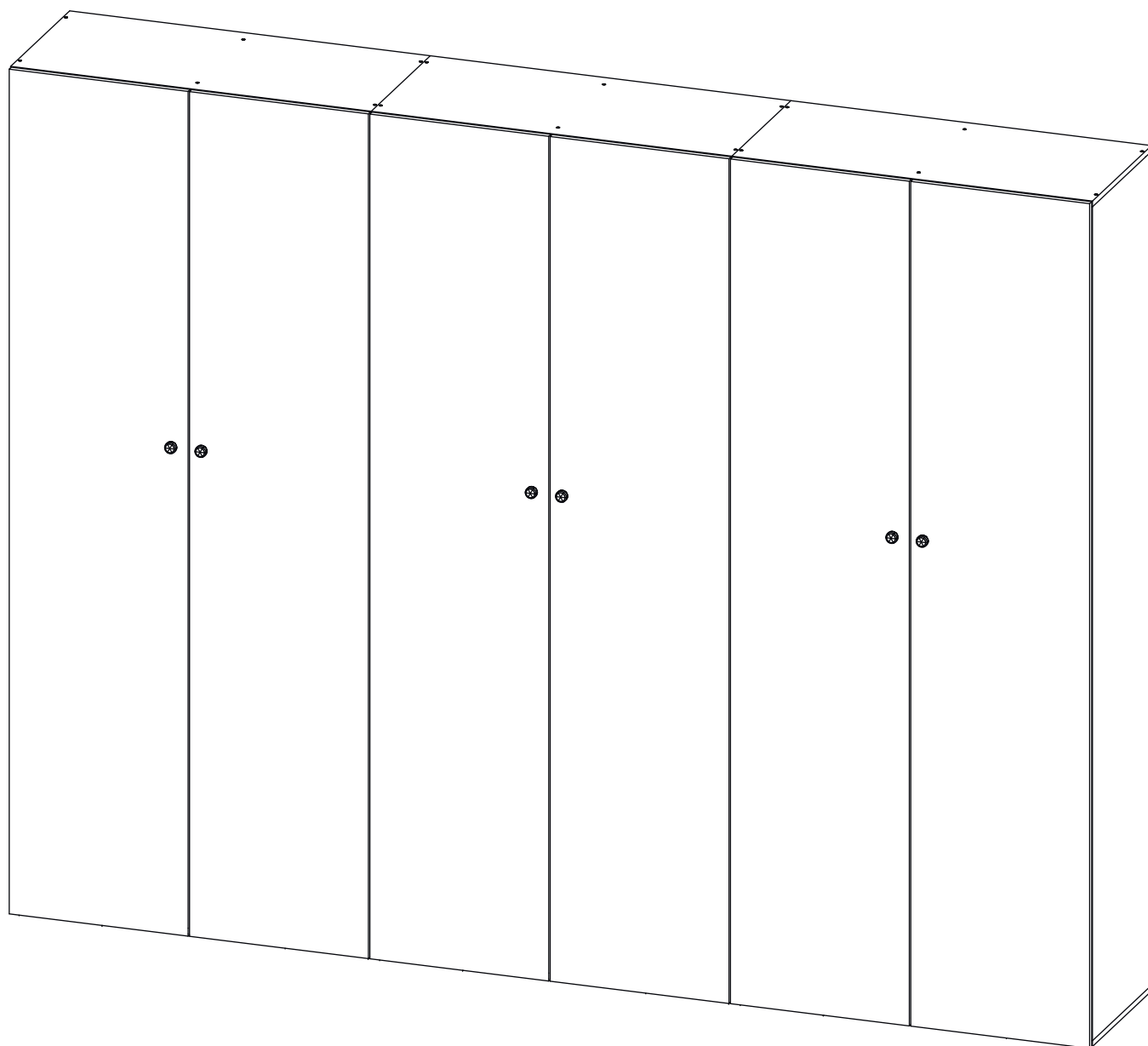

# Детали

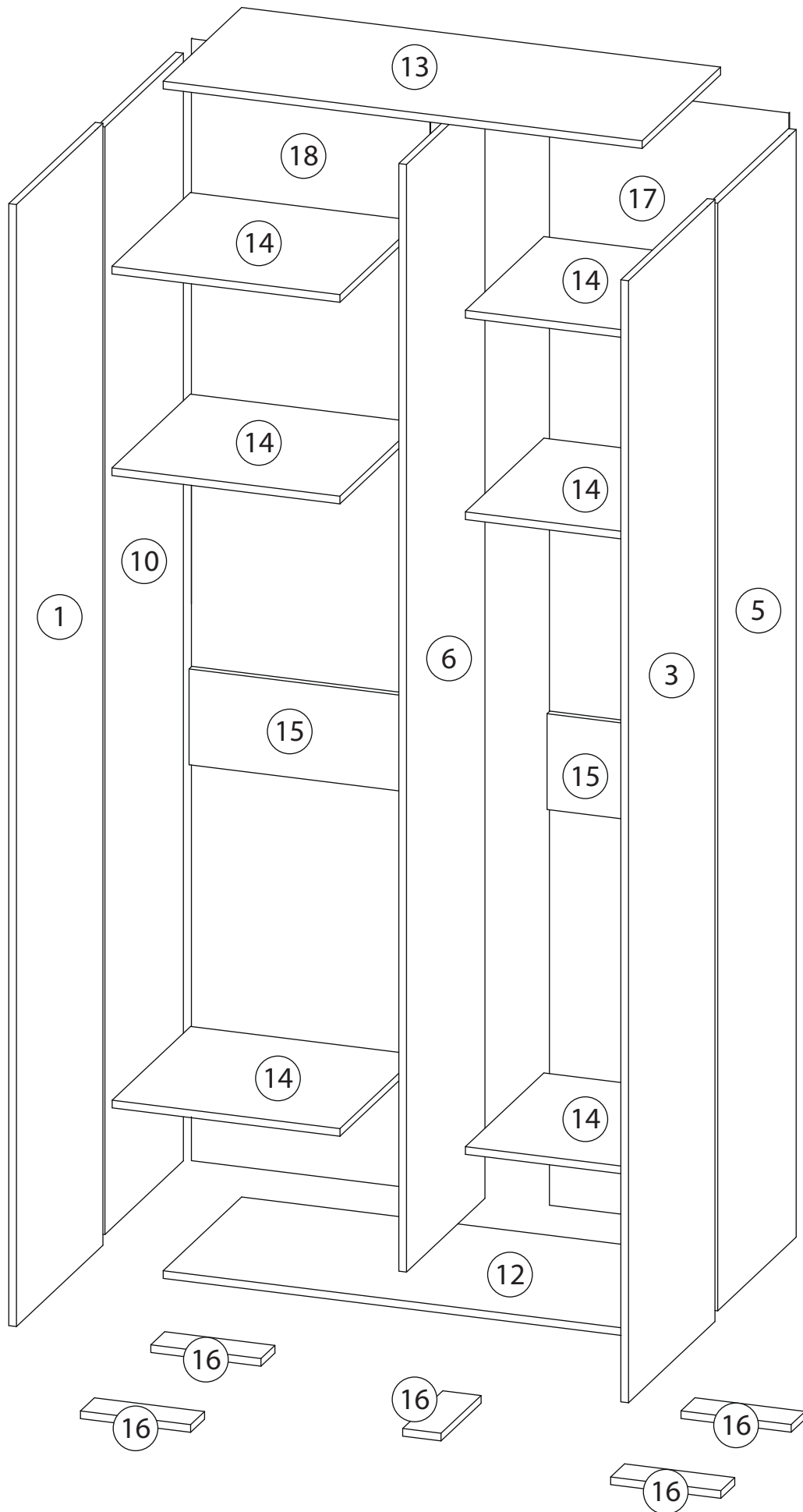



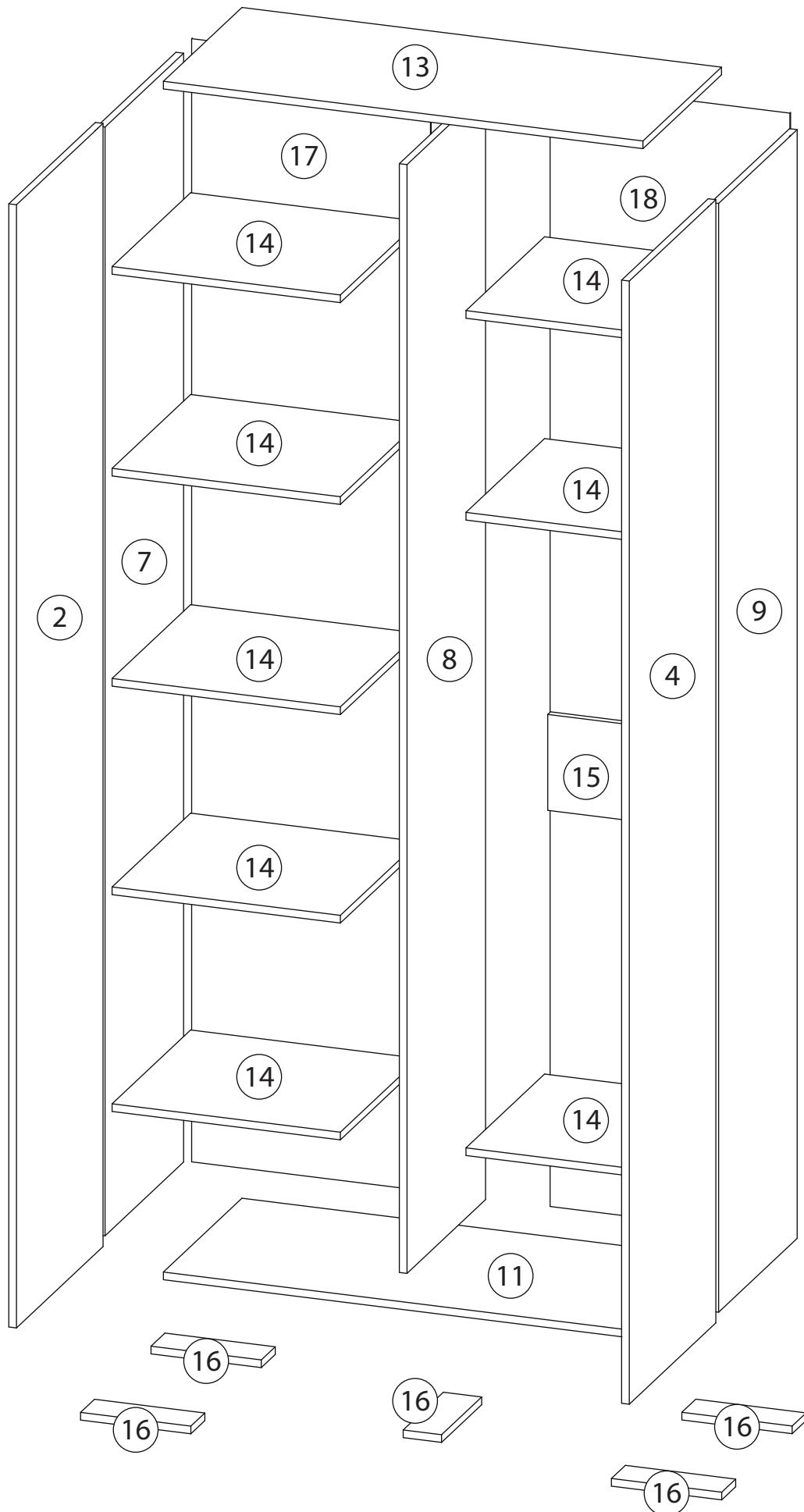

# Детали

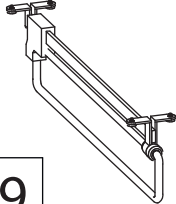
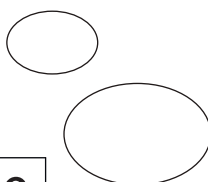
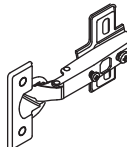
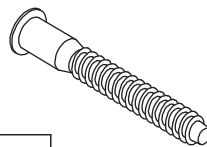
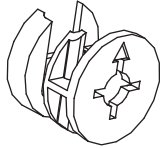
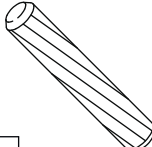
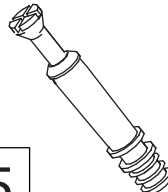

## Детали

Поз.	Наименование	Кол-во	Длина	Ширина
1	Дверь	1	2342	496
2	Дверь	1	2342	496
3	Дверь	1	2342	496
4	Дверь	1	2342	496
5	Бок правый	1	2312	450
6	Вертикаль	1	2312	450
7	Бок левый	1	2312	450
8	Вертикаль	1	2312	450
9	Бок правый	1	2312	450
10	Бок левый	1	2312	450
11	Дно	1	1000	450
12	Дно	1	1000	450
13	Крыша	2	1000	450
14	Полка	14	476	450
15	Ребро жесткости	3	476	200
16	Планка	10	230	80
17	Задняя стенка	2	2342	500
18	Задняя стенка	2	2342	498

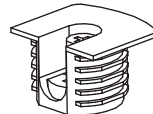
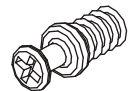
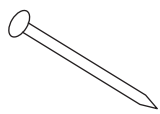
# Фурнитура

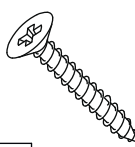
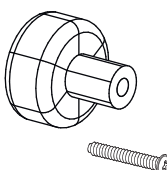
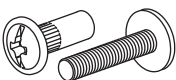
 <b>19</b>	 <b>20</b>	 <b>21</b>	 <b>22</b>	 <b>23</b>
<u>Штанга выдвигающая</u>	<u>Заглушка Ø13-20</u>	<u>Петля накладная</u>	<u>Евровинт 7x50</u>	<u>Эксцентрик</u>
 <b>24</b>	 <b>25</b>	 <b>26</b>	 <b>27</b>	 <b>28</b>
<u>Шкант бук</u>	<u>Шток эксцентрика</u>	<u>Евровинт 6,3x13</u>	<u>Стяжка VB35</u>	<u>Винт для стяжки VB35</u>
 <b>29</b>	 <b>30</b>	 <b>31</b>	 <b>32</b>	
<u>Гвоздь 1,6x25</u>	<u>Саморез 3,5x16</u>	<u>Саморез 3,5x30</u>	<u>Ручка кнопка</u>	
 <b>33</b>				
<u>Стяжка межсекционная</u>				

# 1

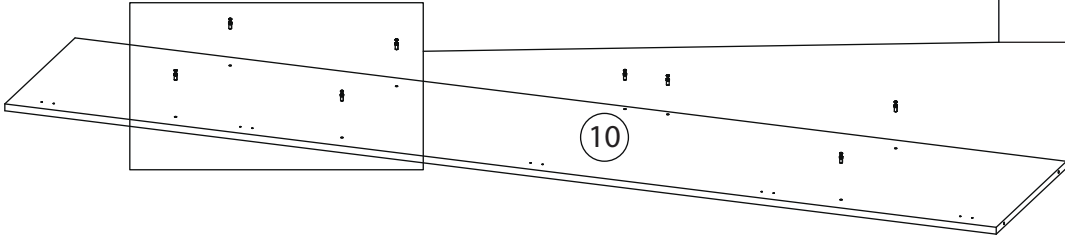
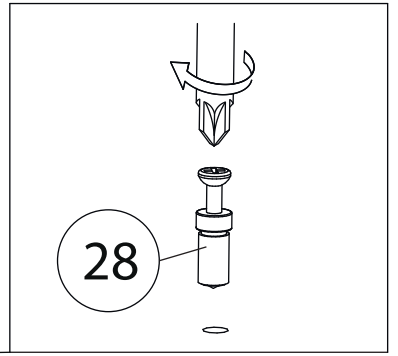

# 2

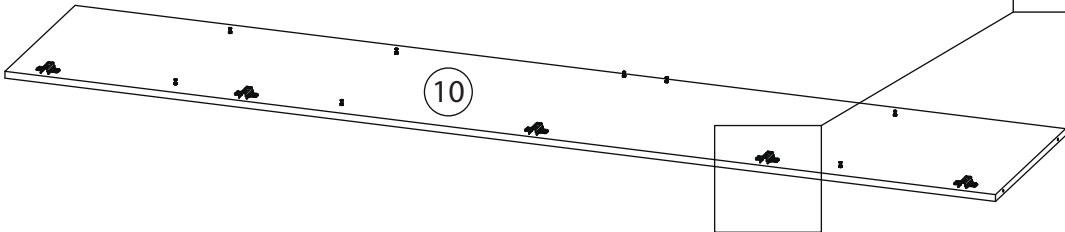
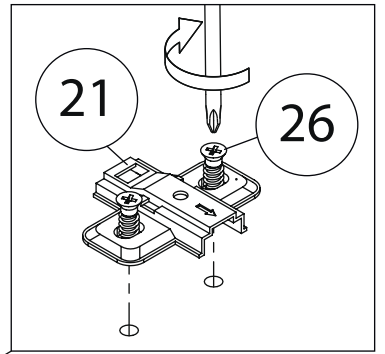

# 3

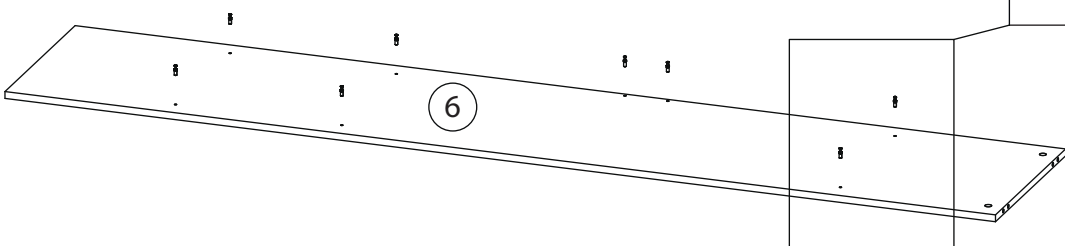
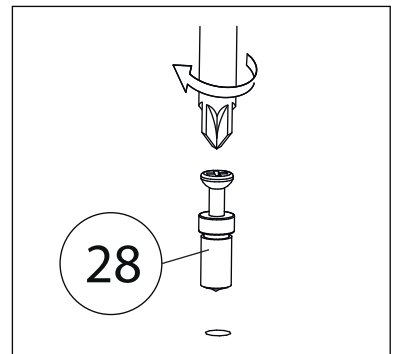

# 4

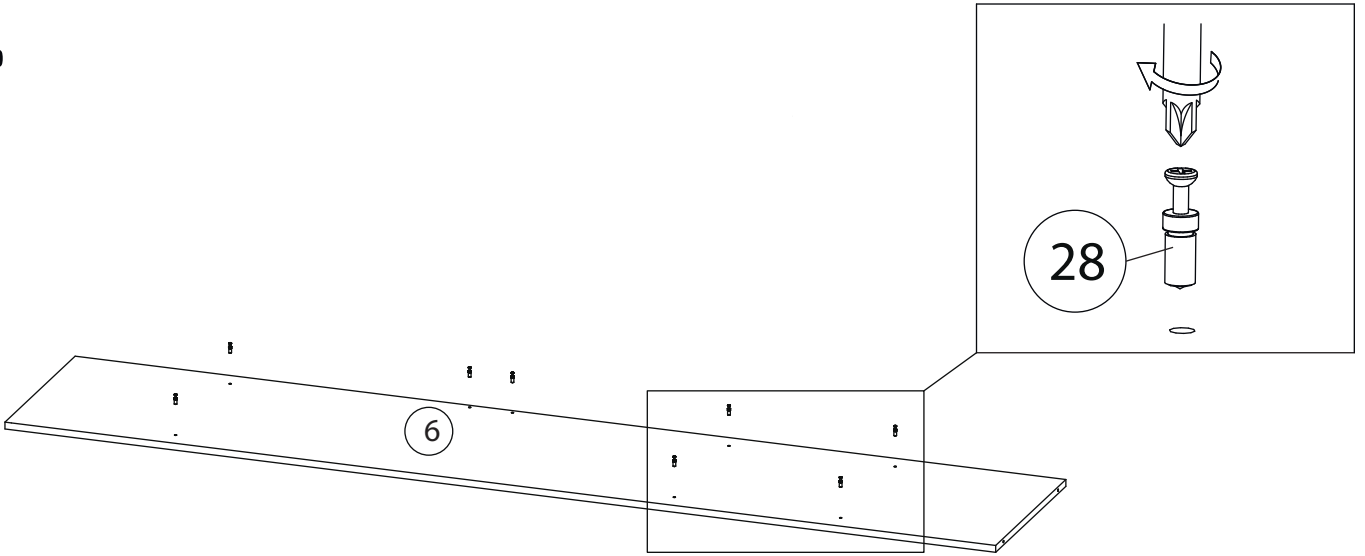

# 5

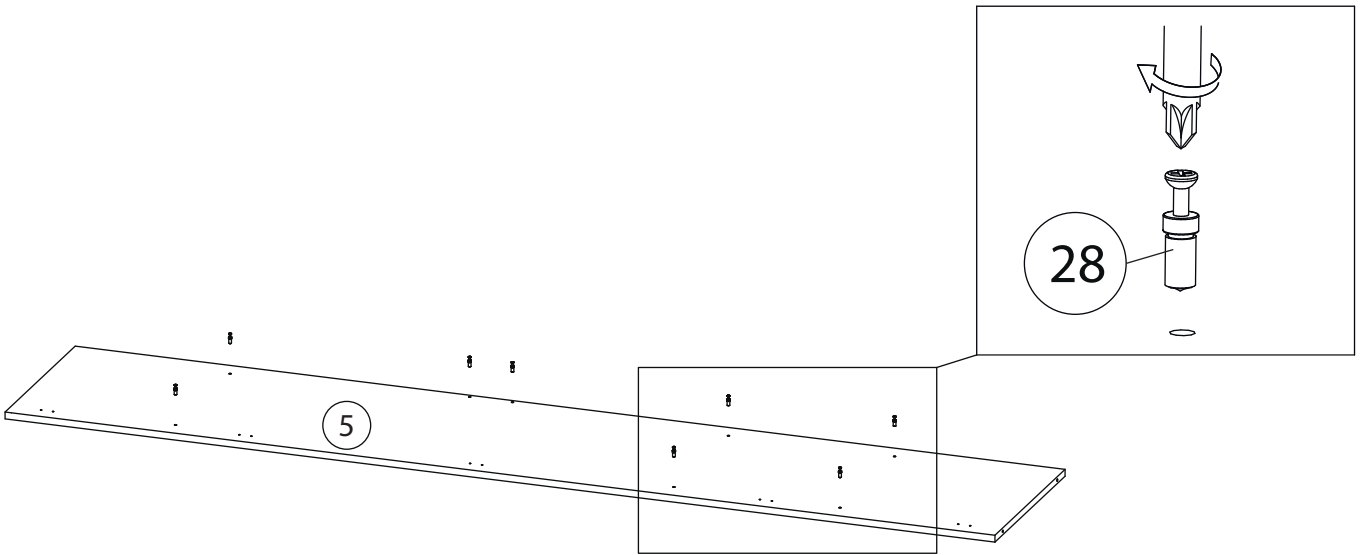

# 6

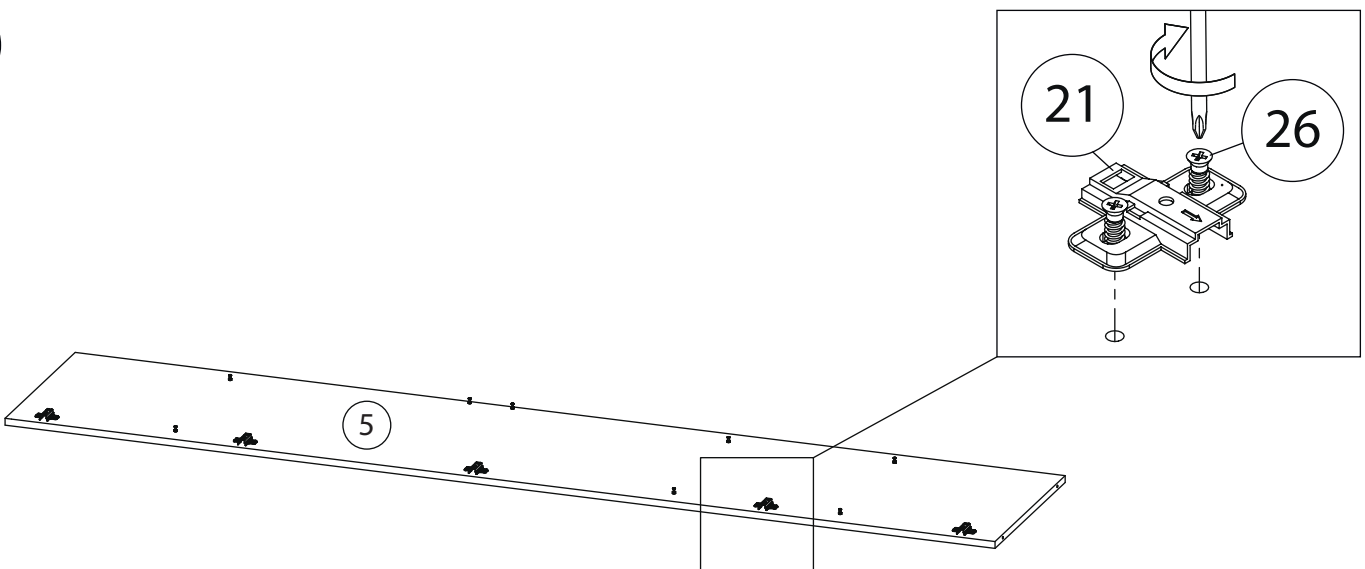

# 7

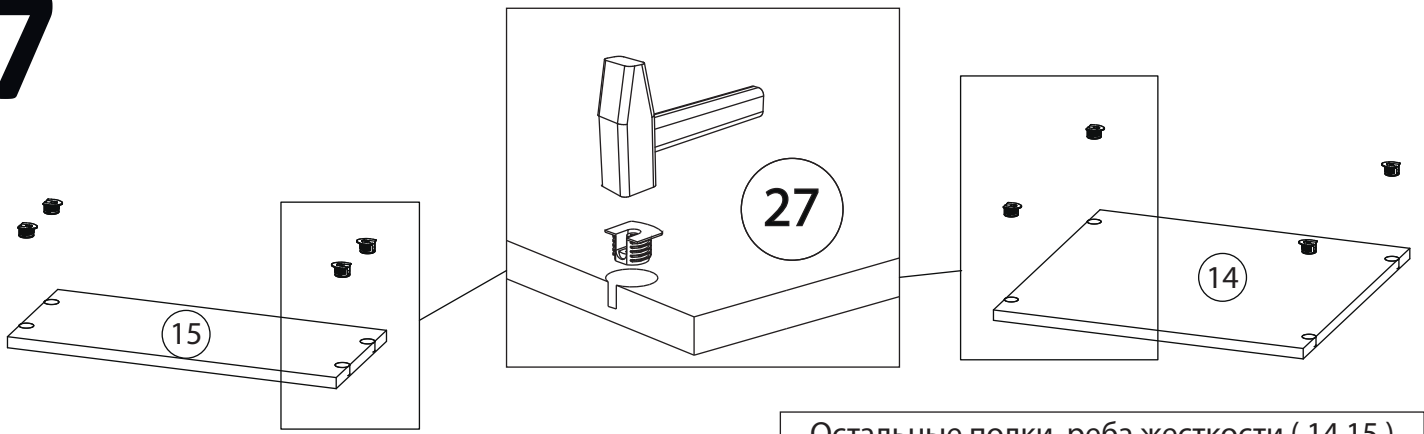

Остальные полки, ребра жесткости ( 14,15 )  
собираются аналогично

# 8

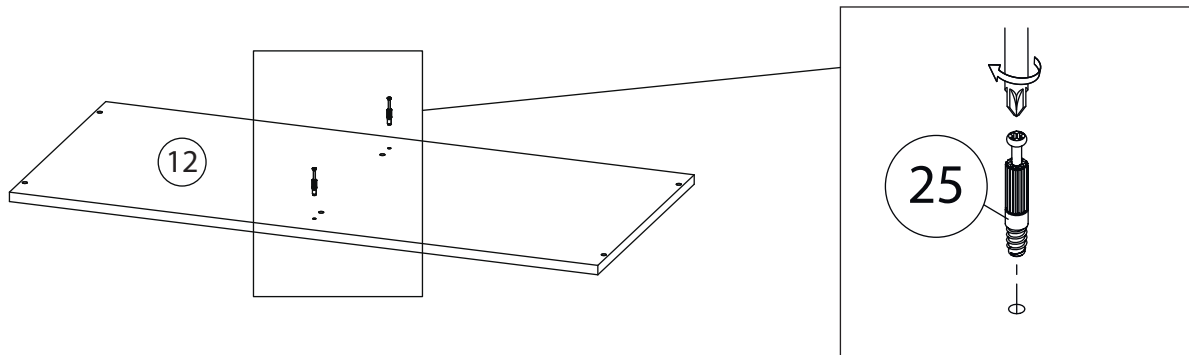

# 9

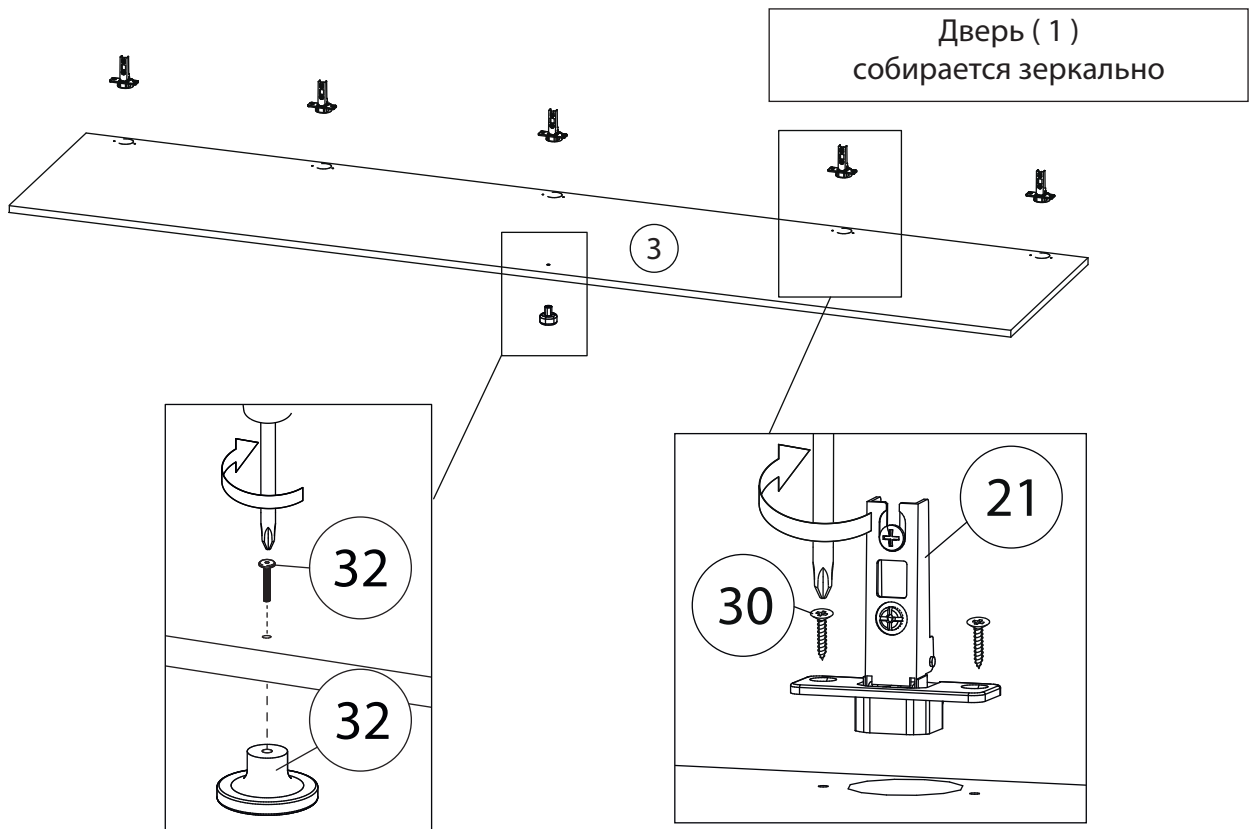

Дверь ( 1 )  
собирается зеркально

# 10

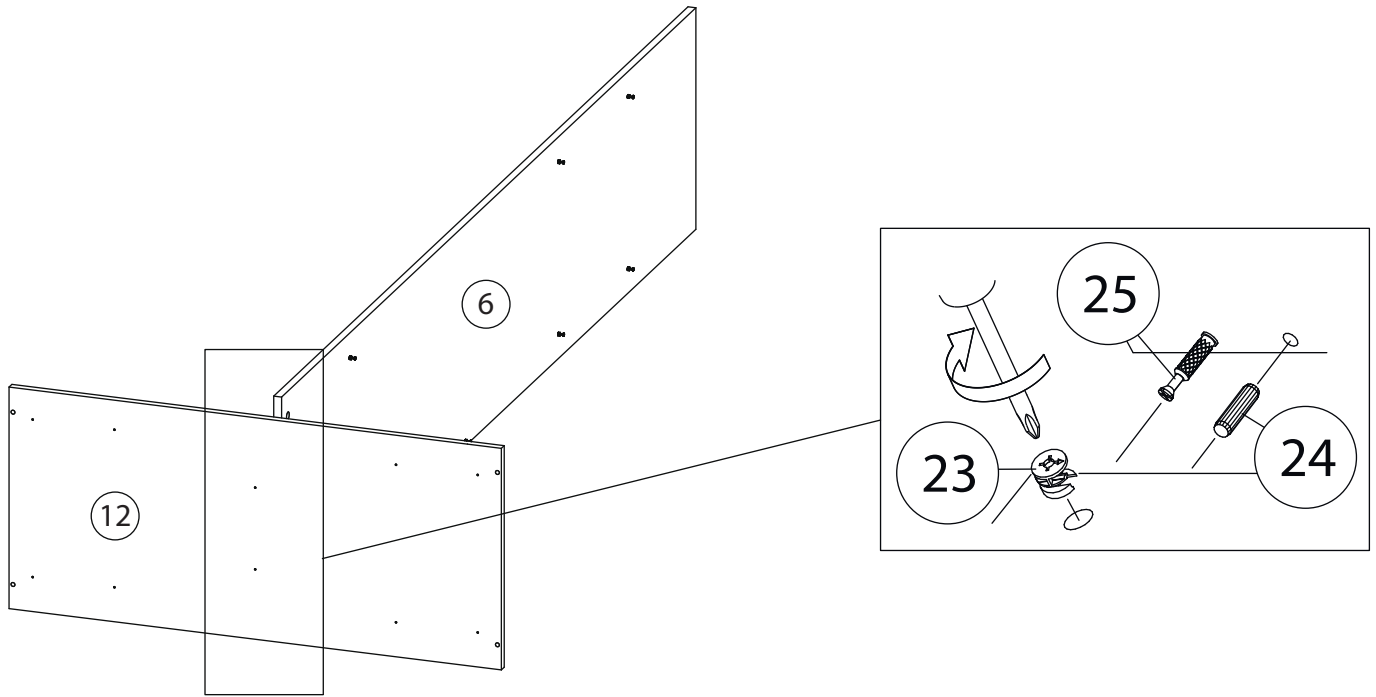

# 11

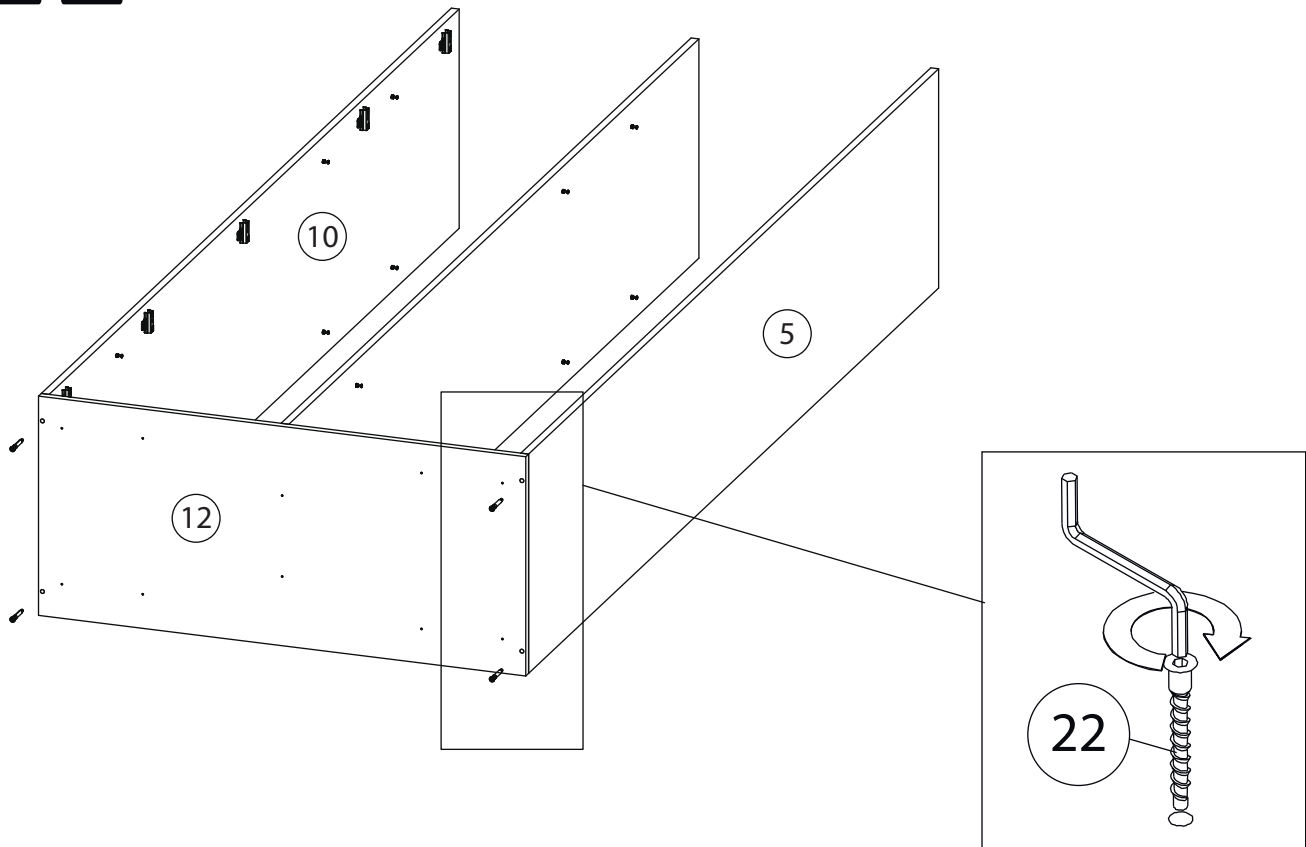

# 12

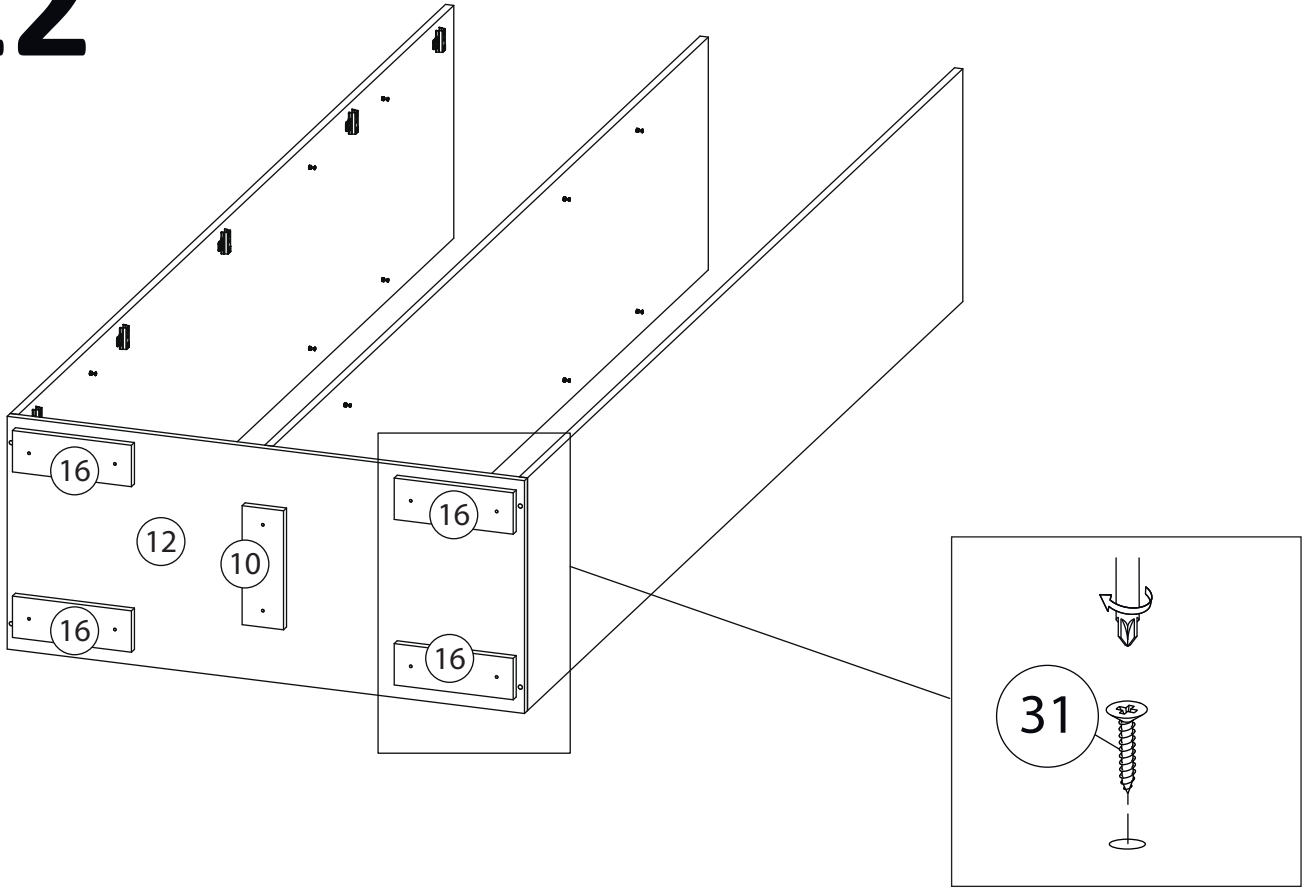

# 13

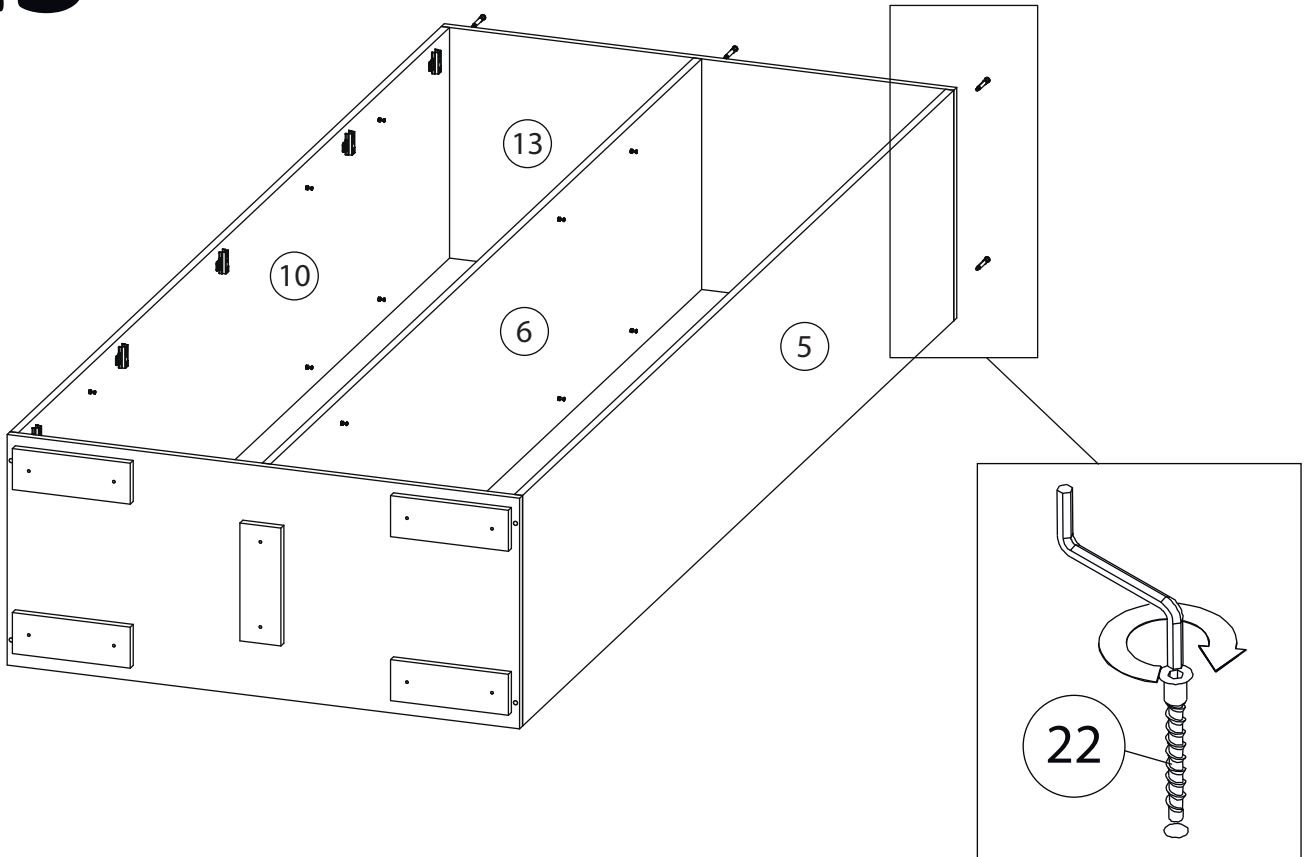

# 14

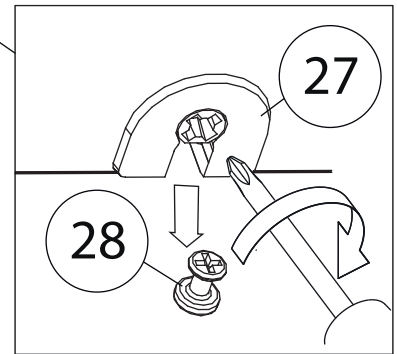
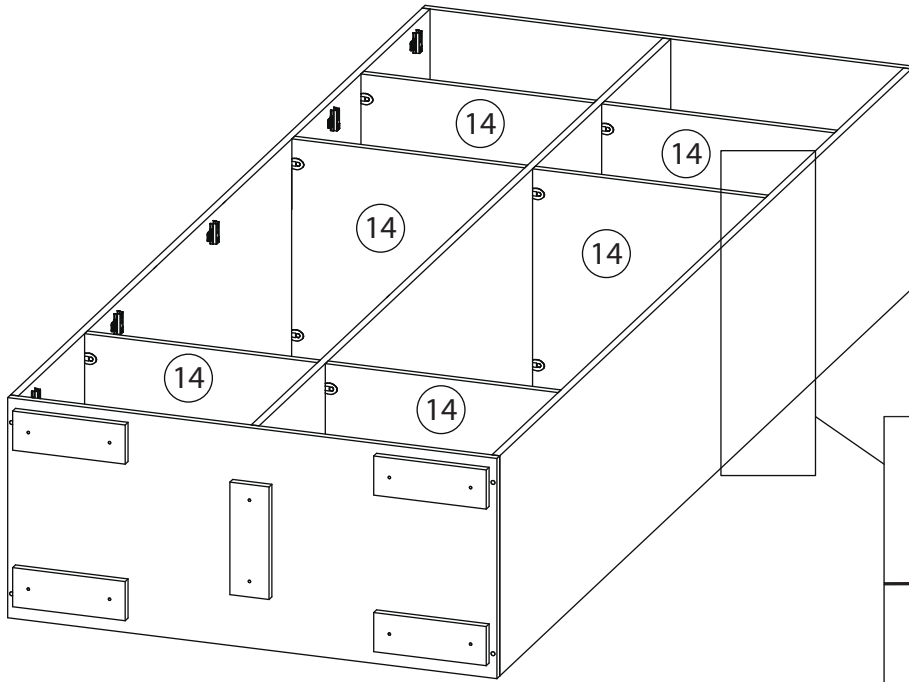

# 15

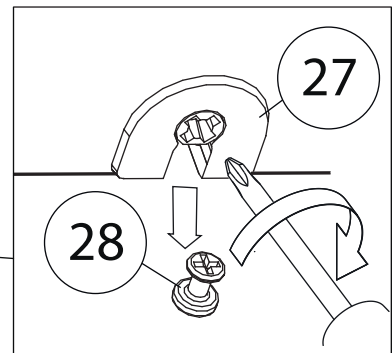
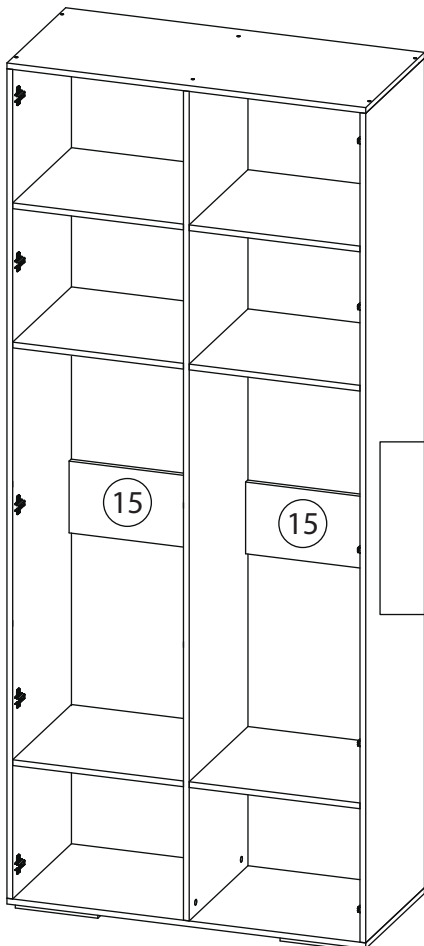

# 16

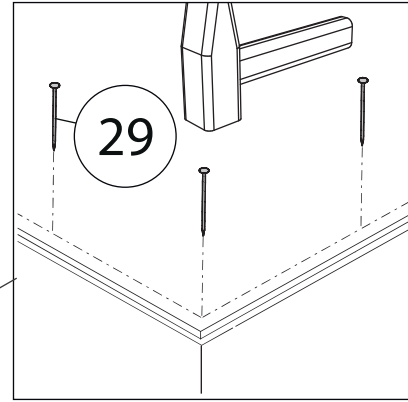
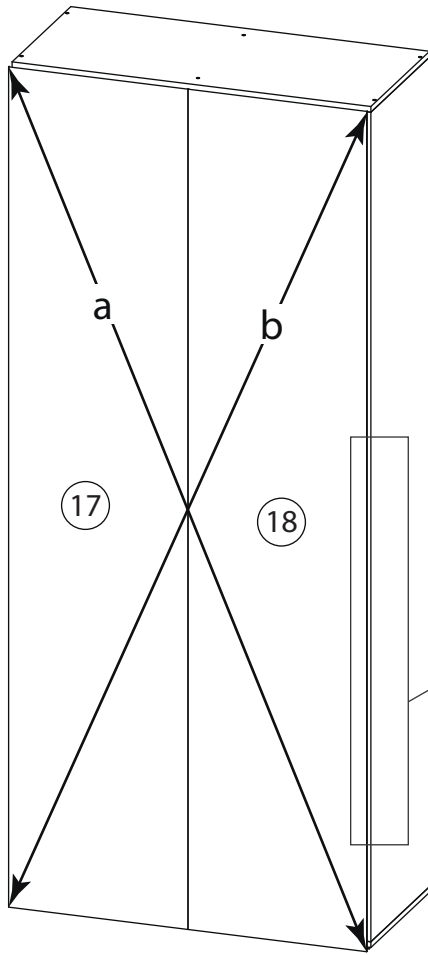

# 17

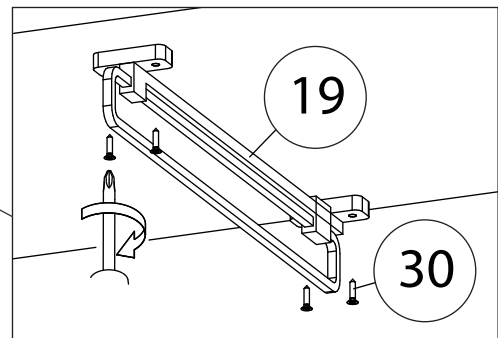
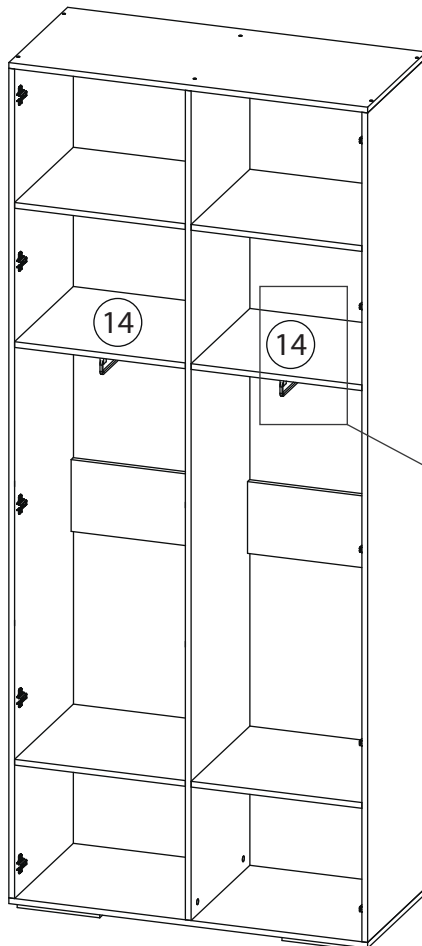

# 18

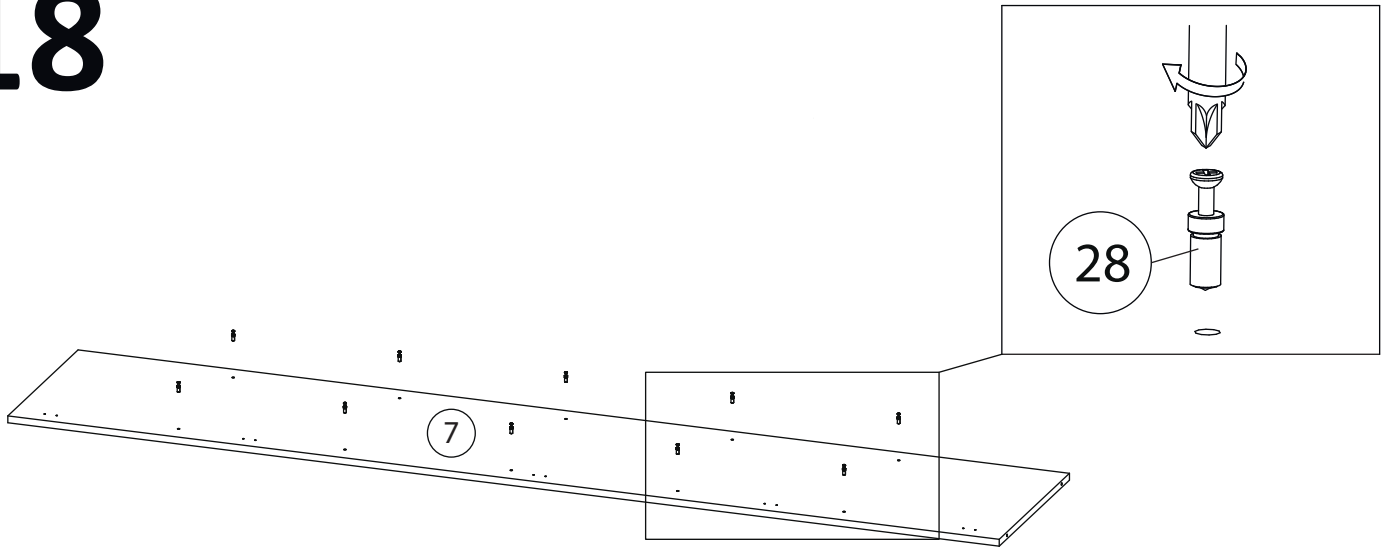

# 19

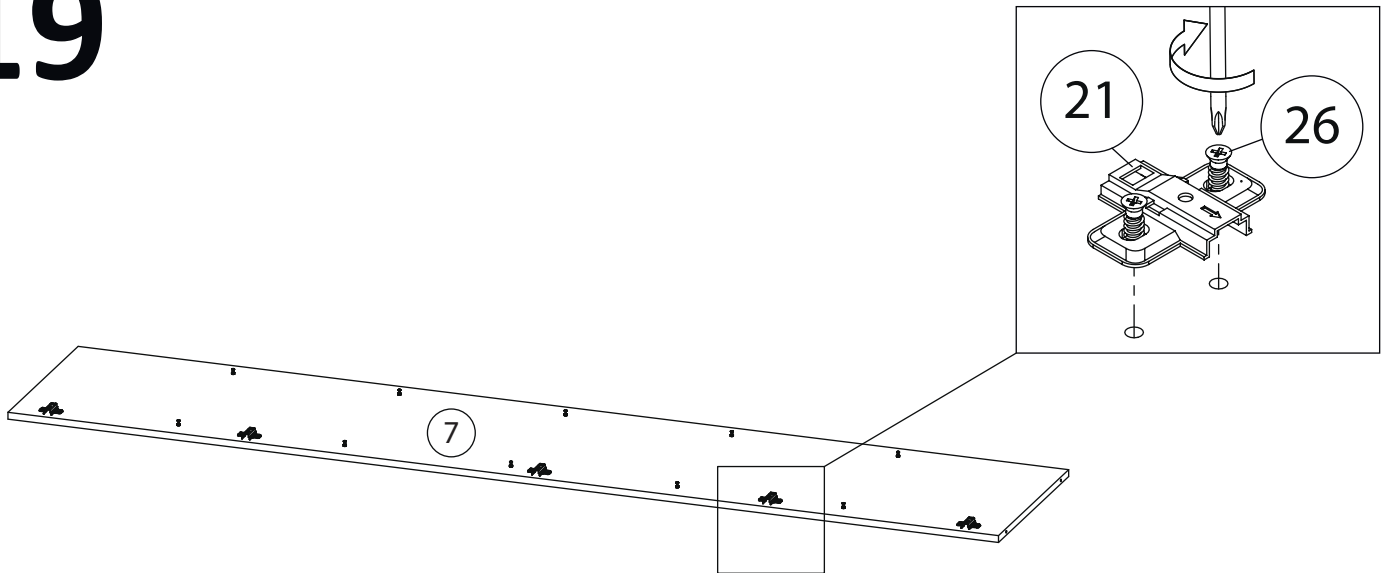

# 20

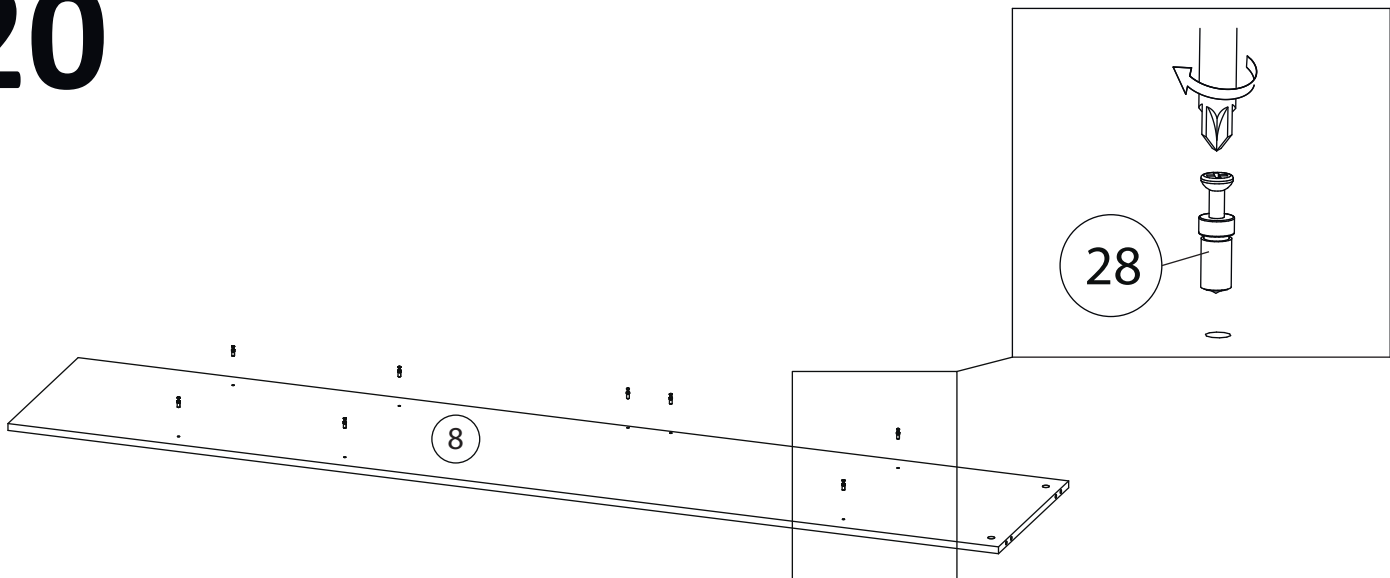

# 21

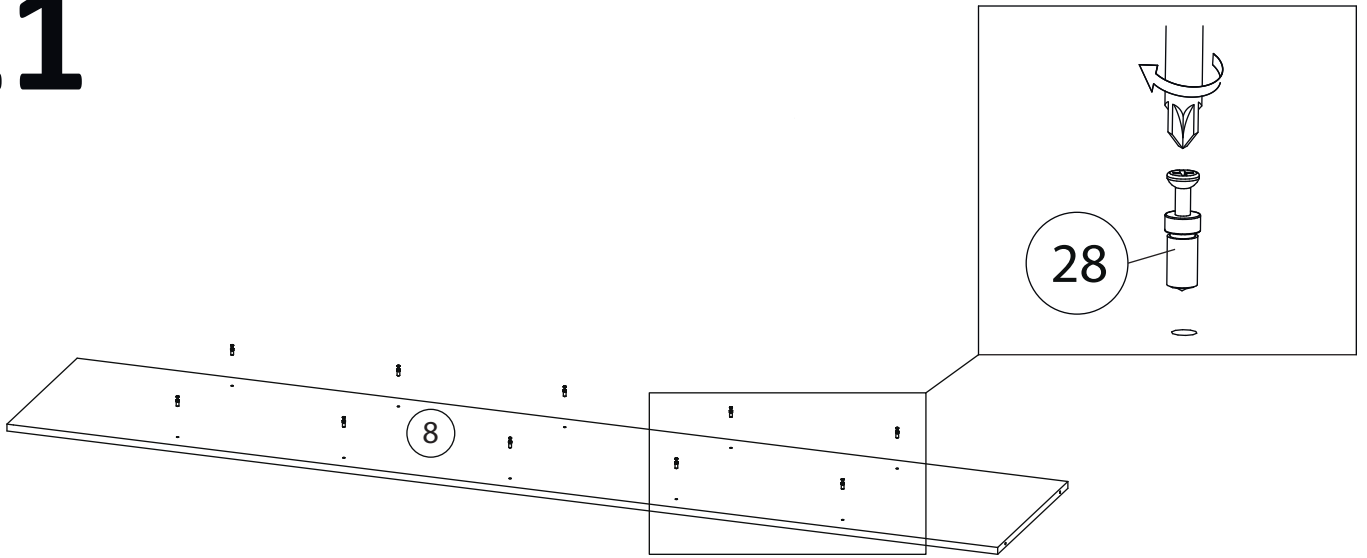

# 22

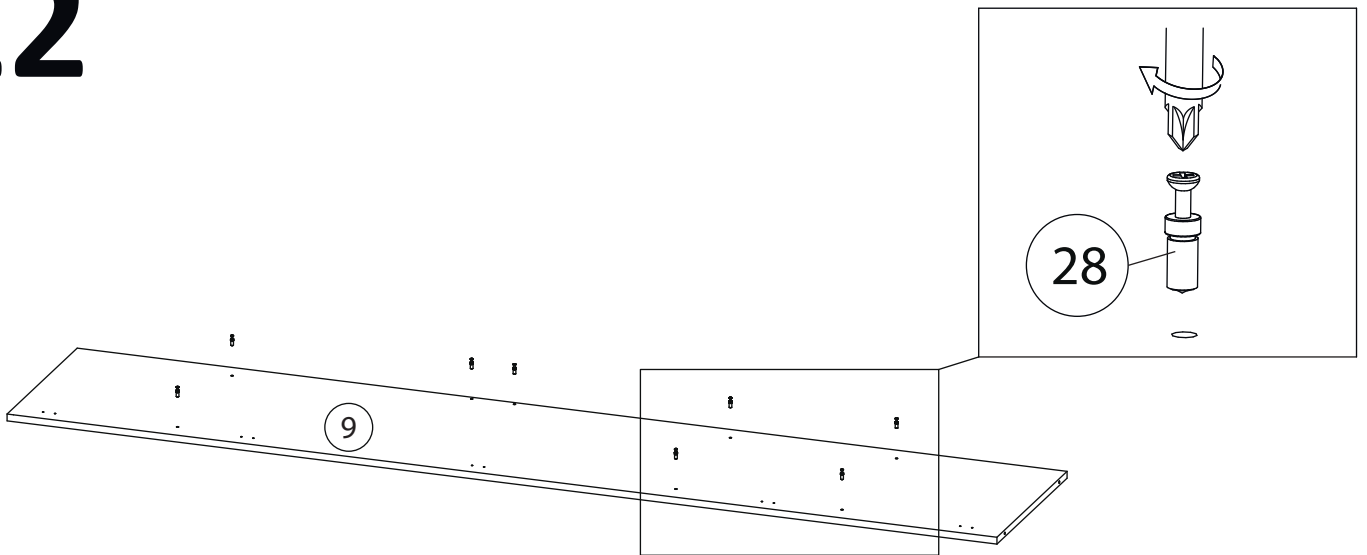

# 23

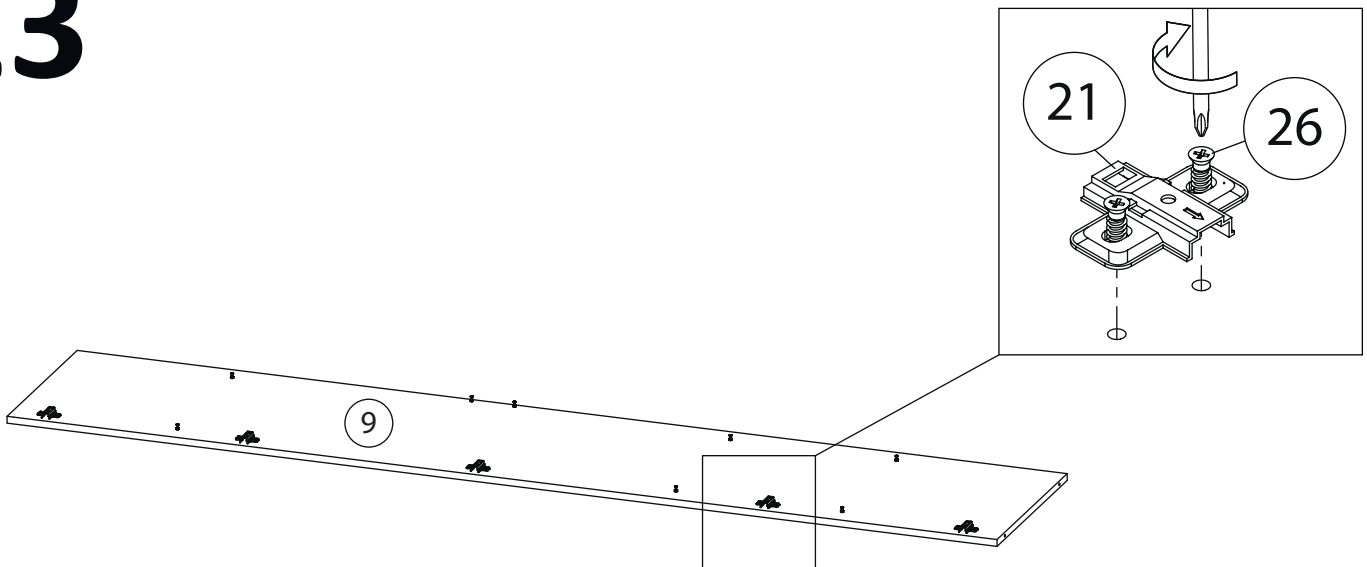

# 24

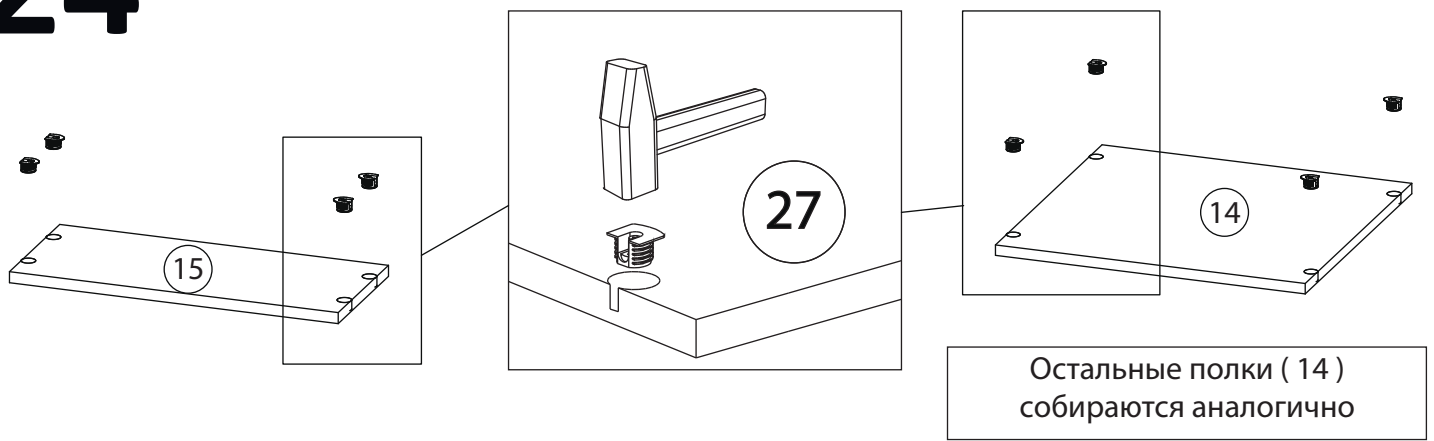

# 25

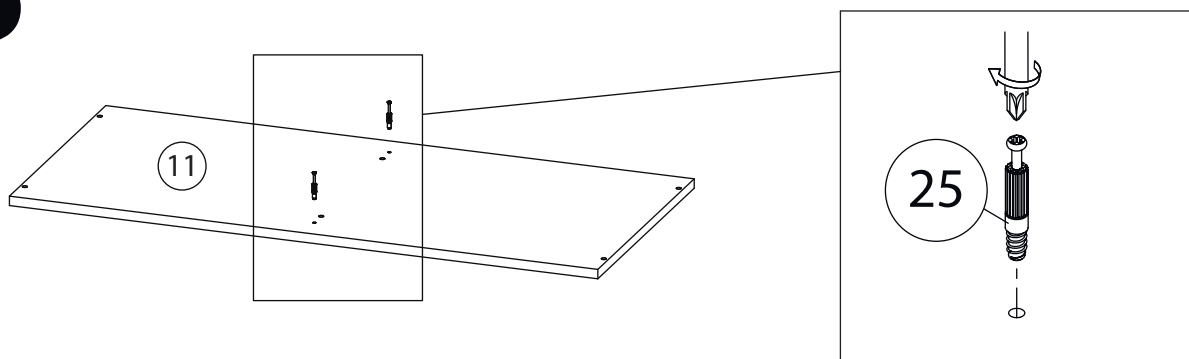

# 26

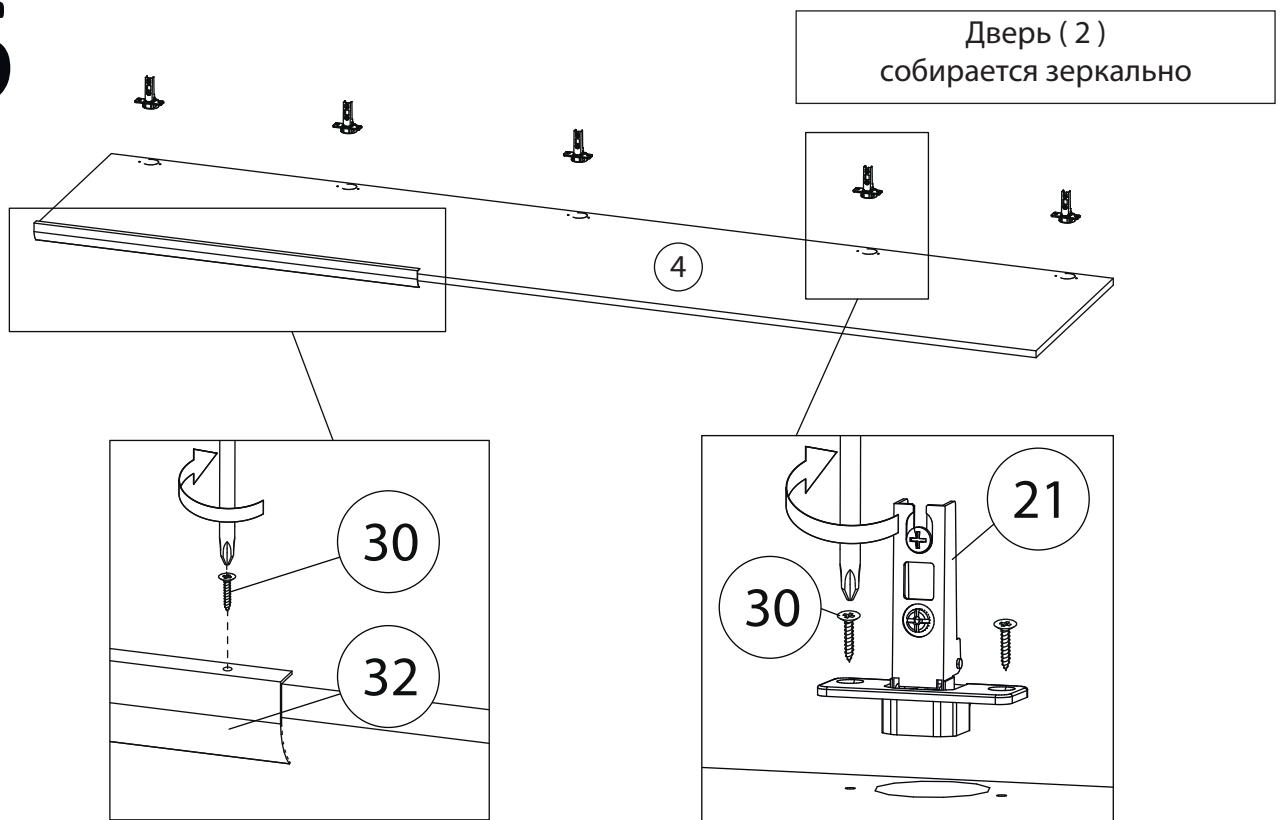

# 27

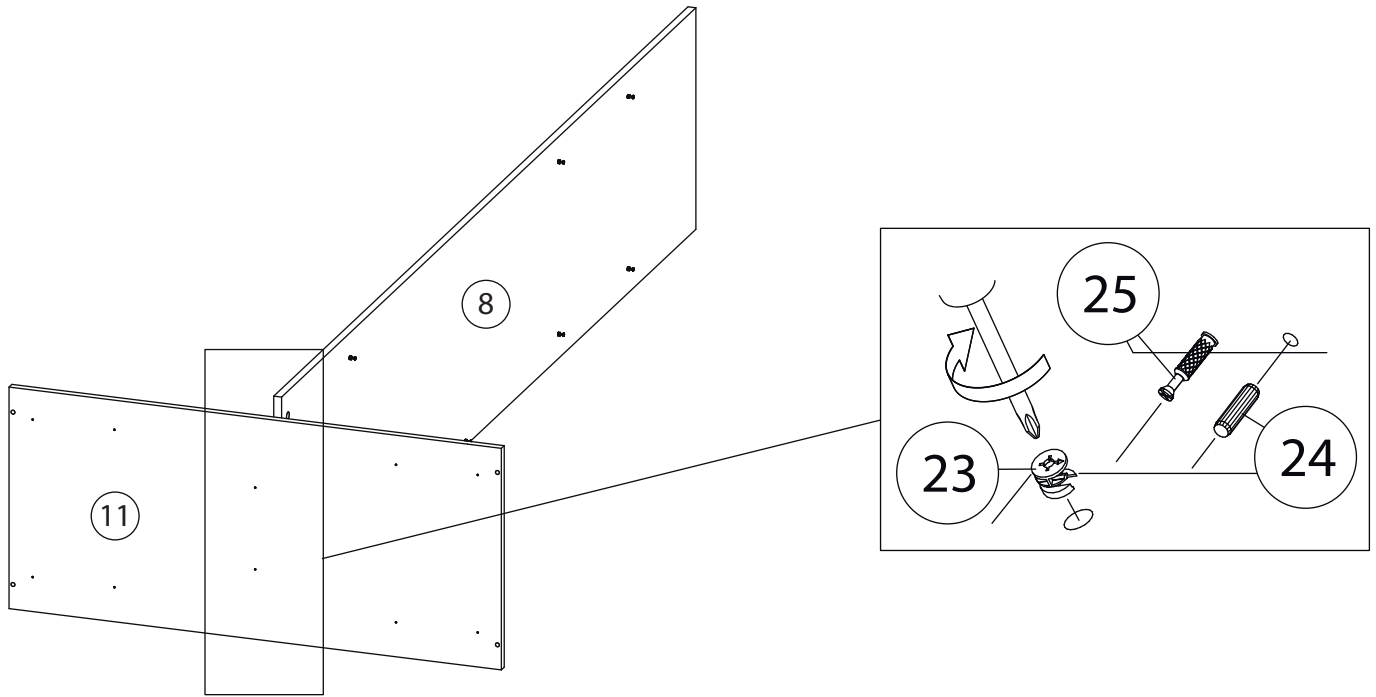

# 28

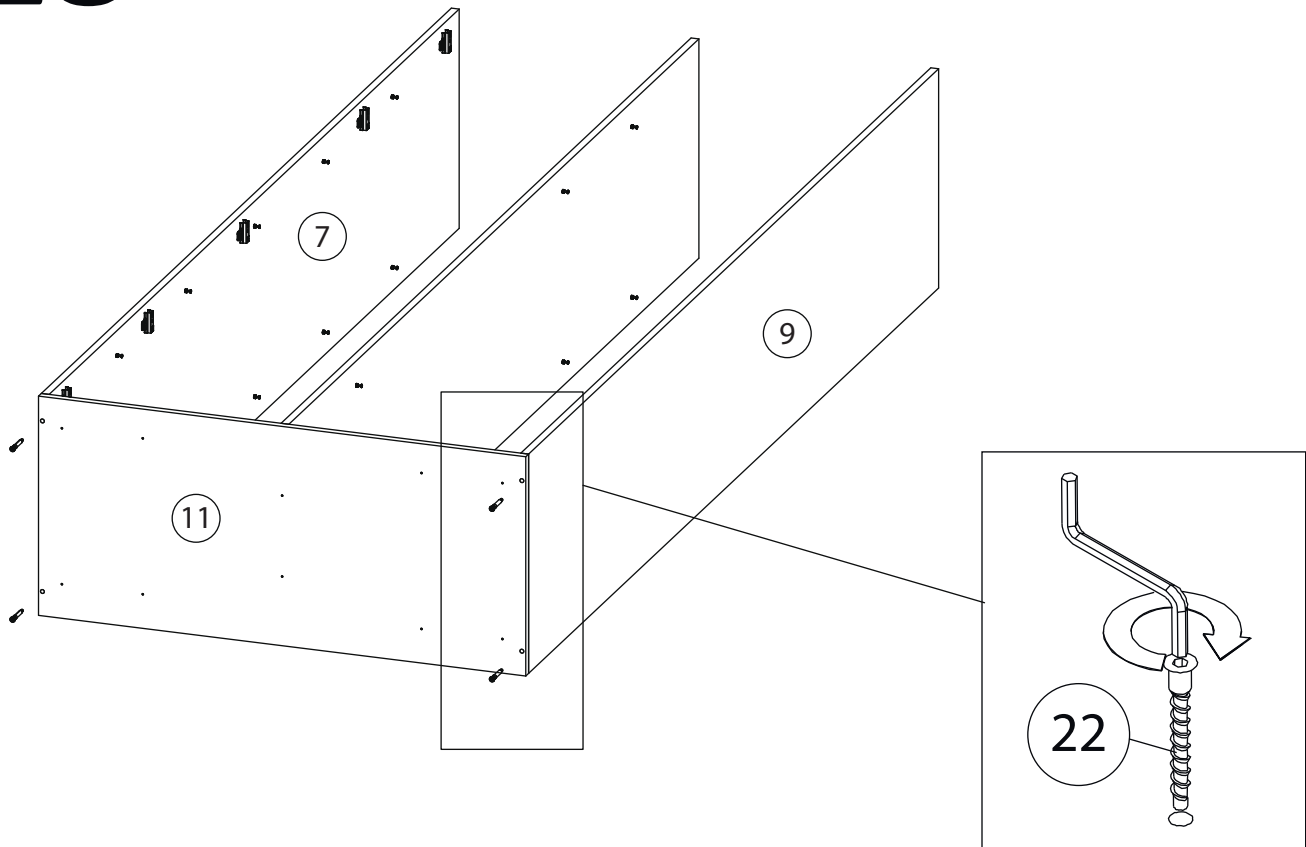

# 29

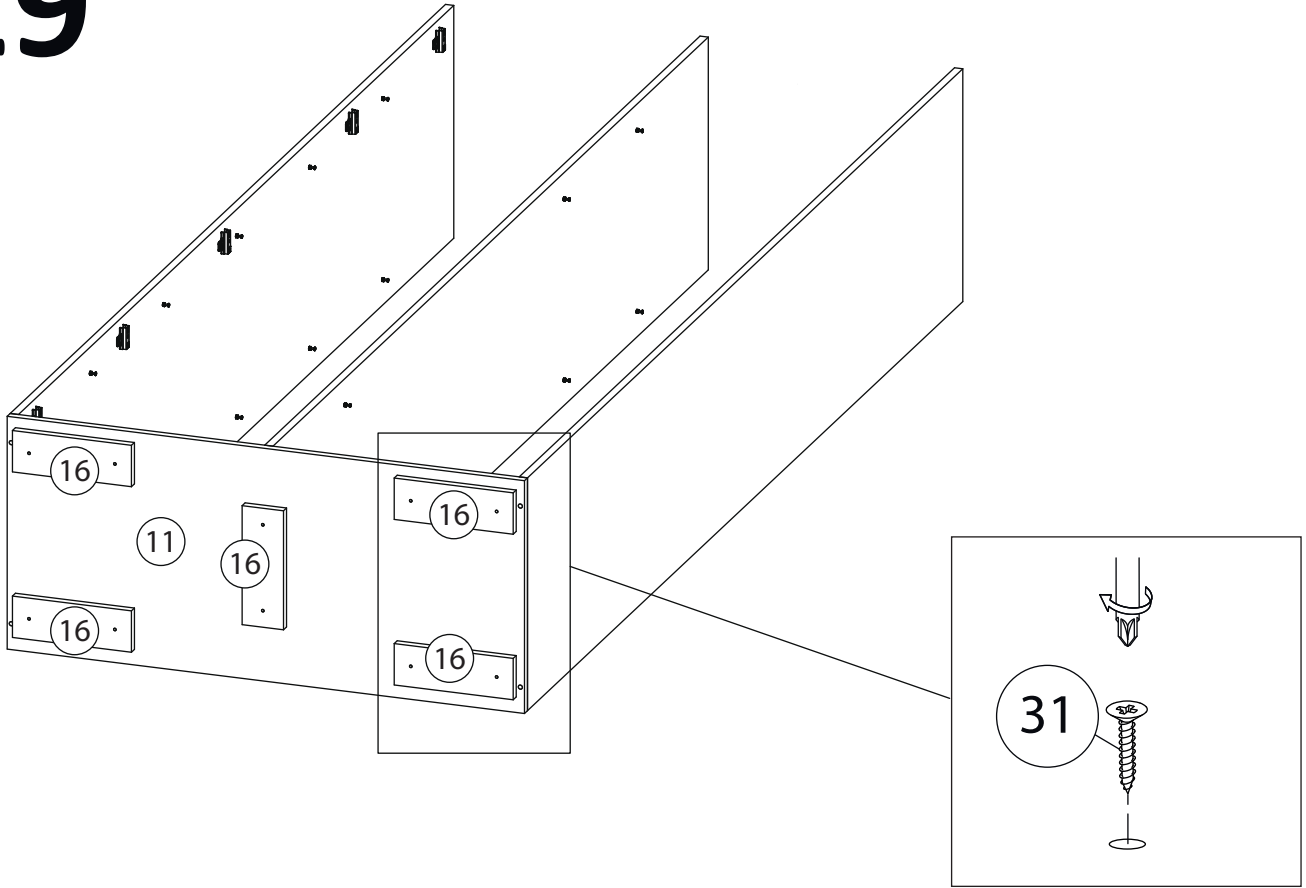

# 30

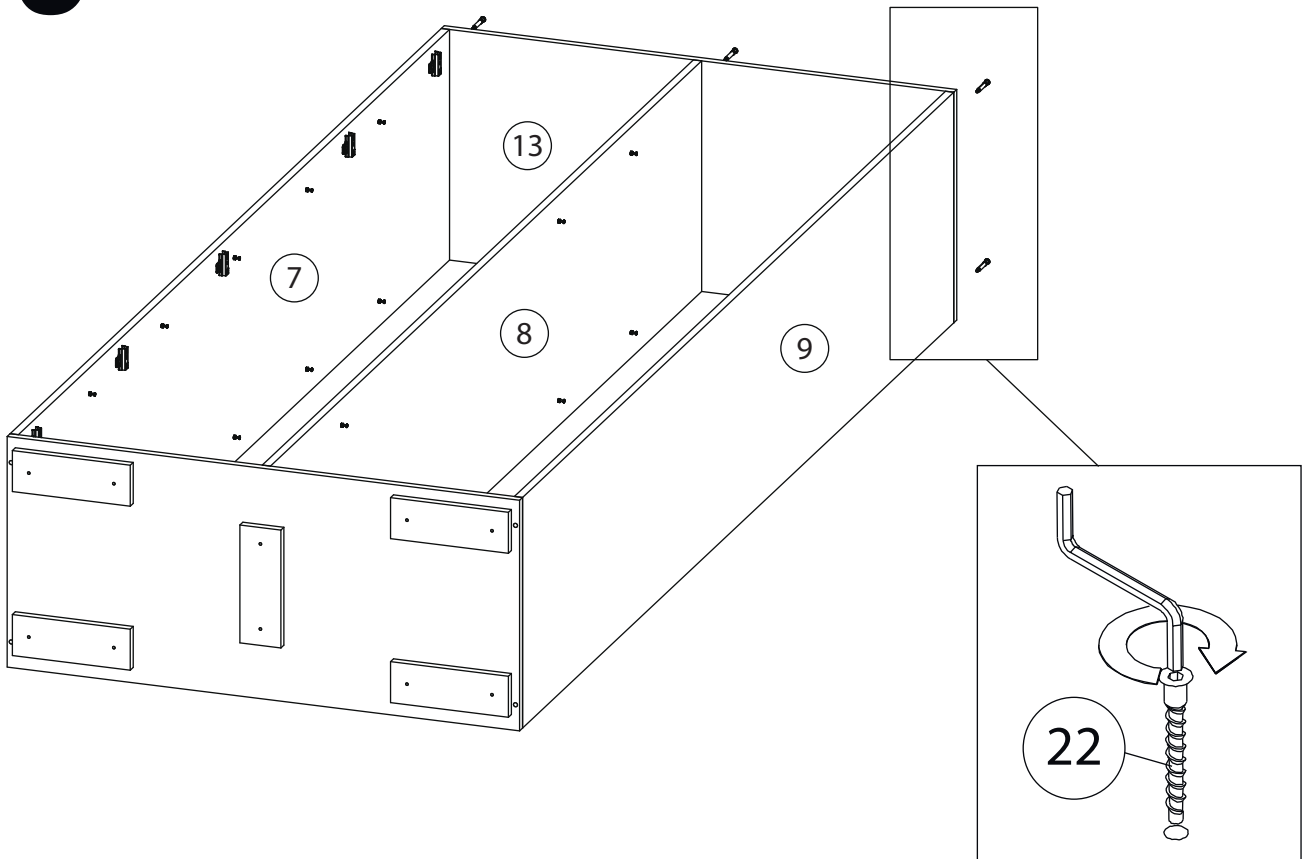

# 31

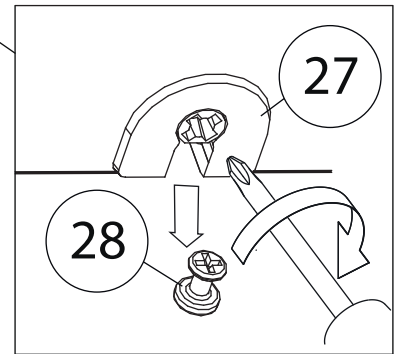
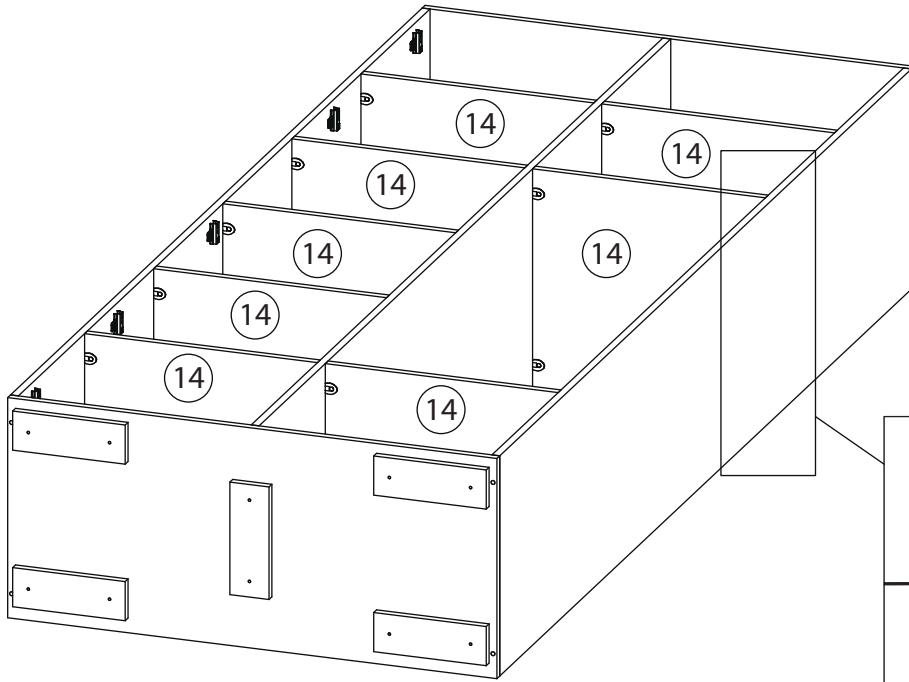

# 32

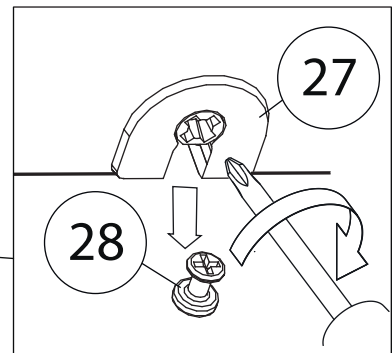
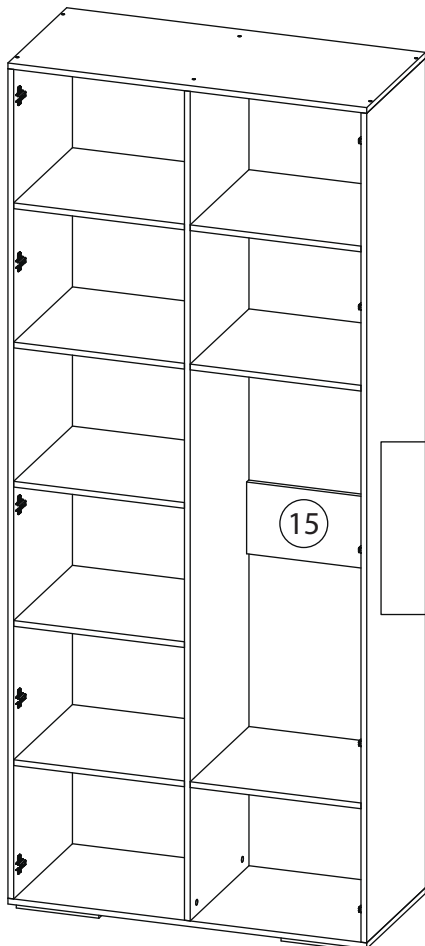

# 33

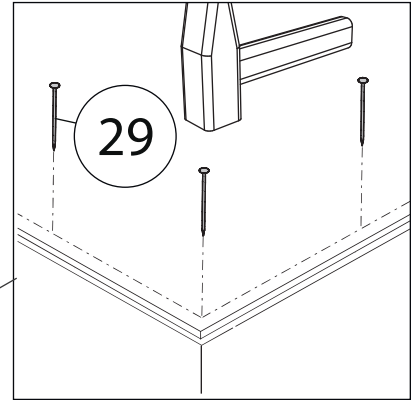
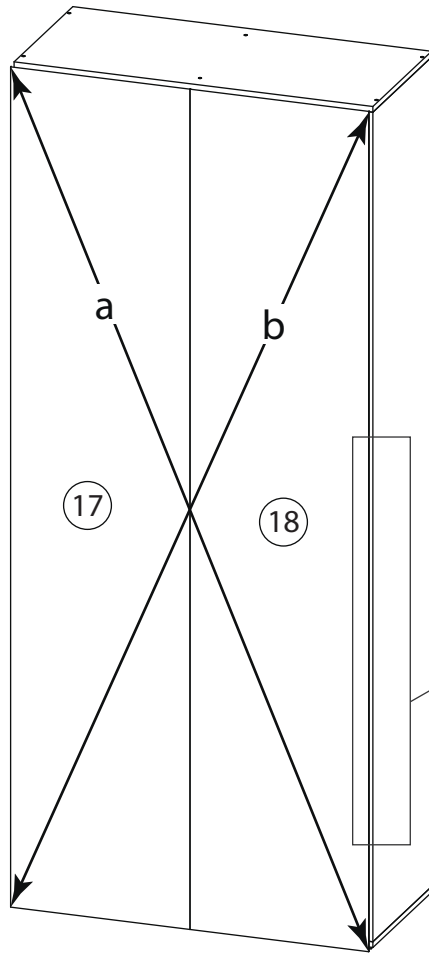

$a=b$

# 34

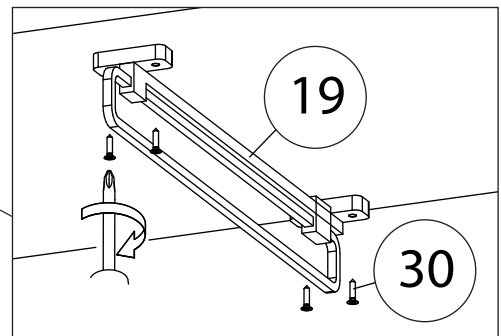
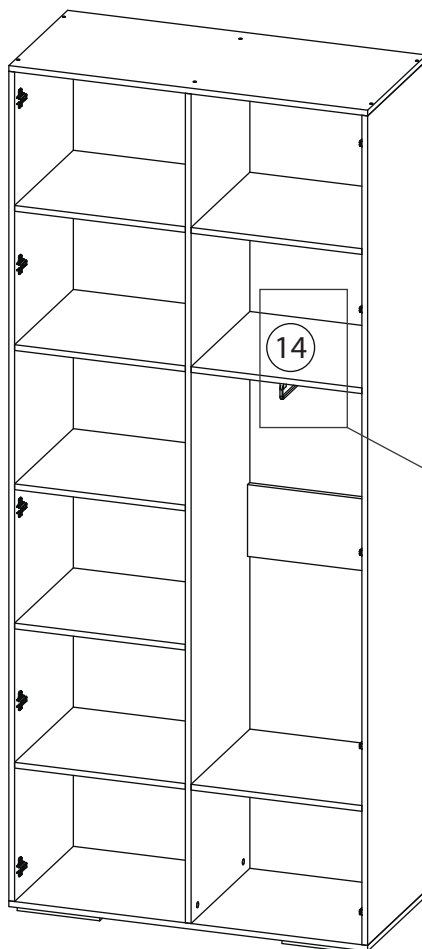

# 35

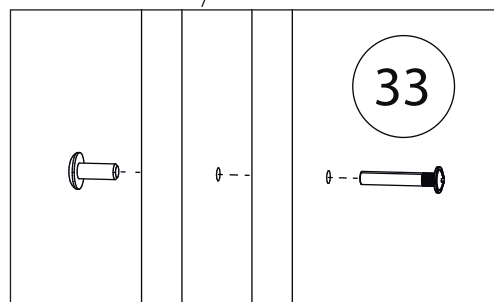
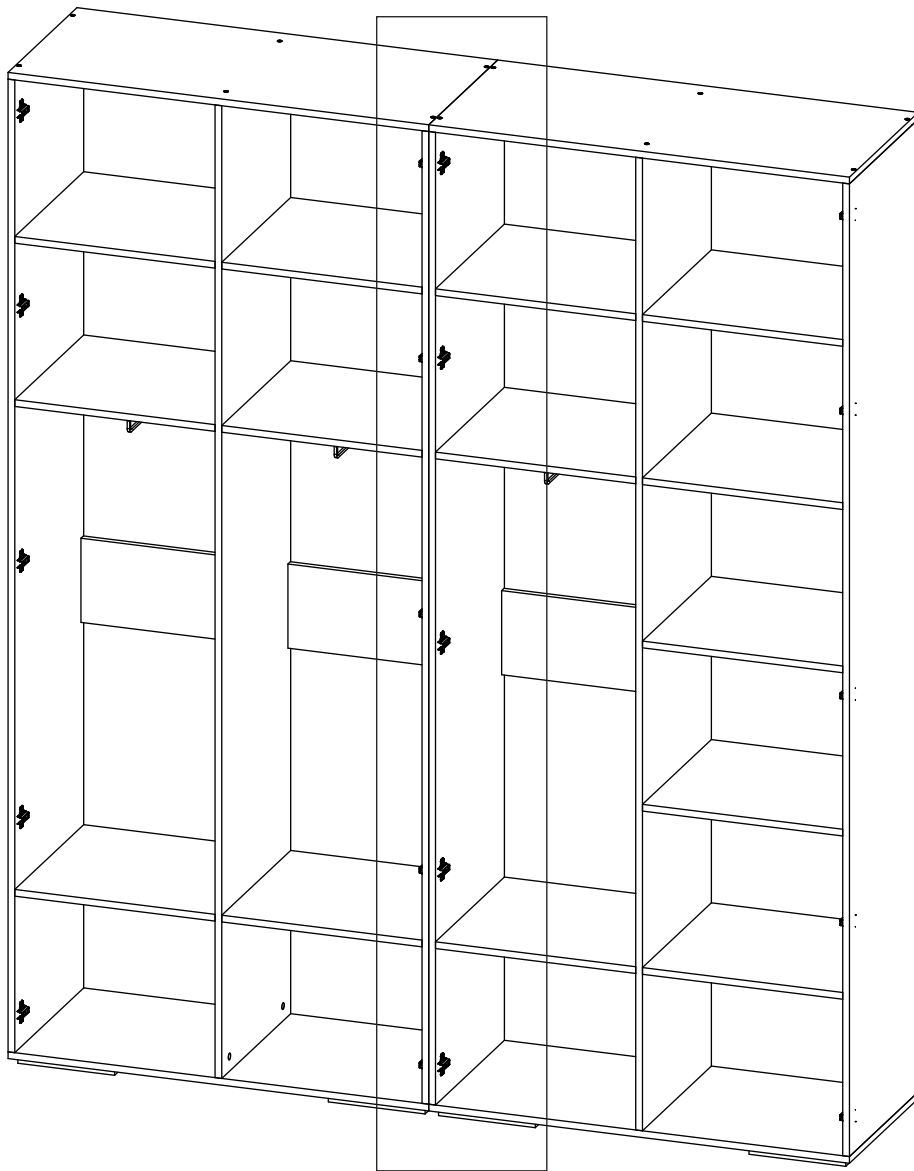

Два модуля стягиваются между собой межсекционными стяжками ( 33 ).  
Предварительно в соприкасающихся боковинах просверливаются сквозные отверстия диаметром 5мм, в произвольном месте, под стяжки

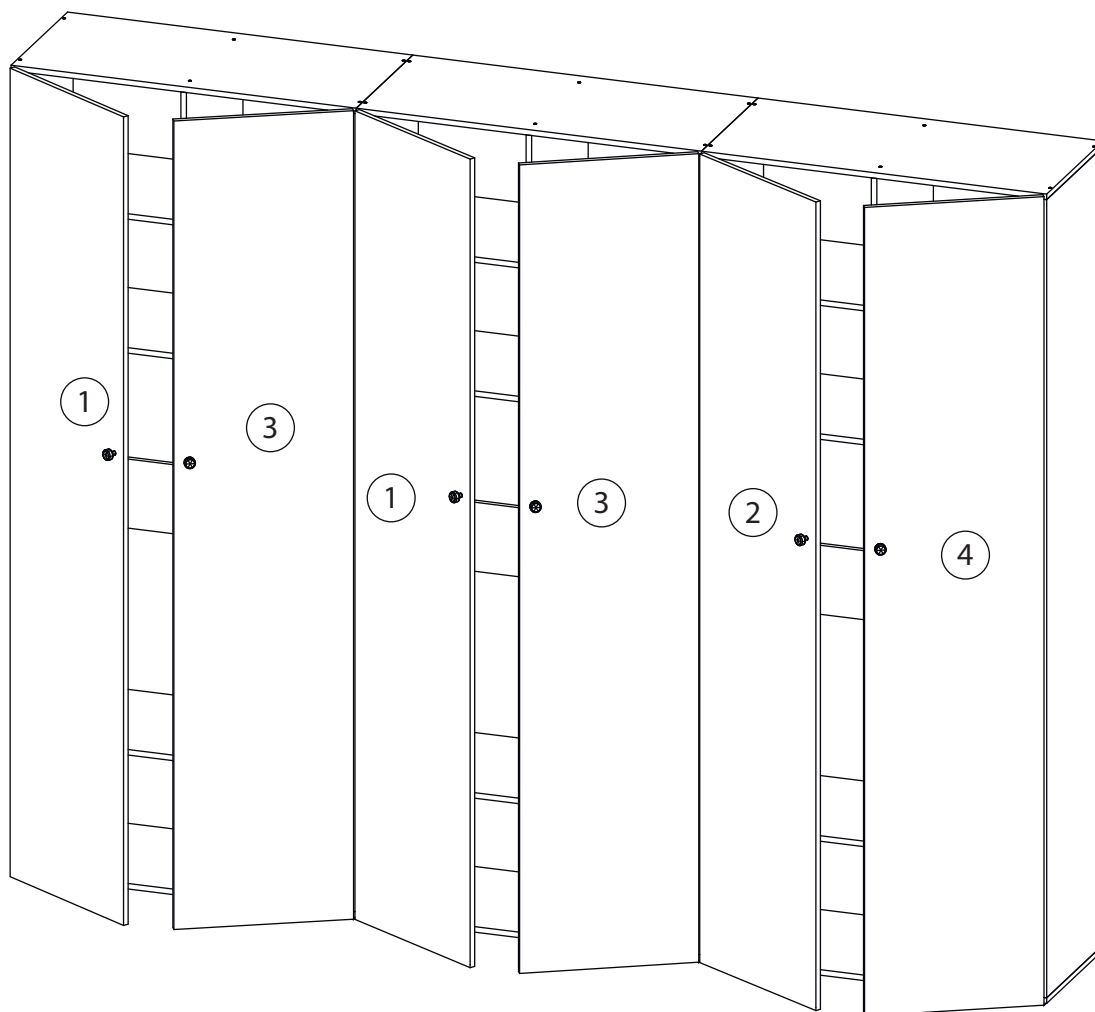

Заклеить технические отверстия заглушками.

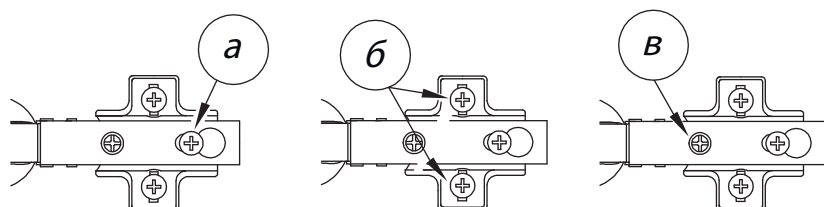

## Регулировка петель

а - регулировка расстояния между дверью и корпусом  
б - регулировка положения двери по-вертикали  
в - регулировка положения ТТдвери по-горизонтали